

User manual

K-BUS KNX Commissioning_V1.6

BBPS-02/USB.1

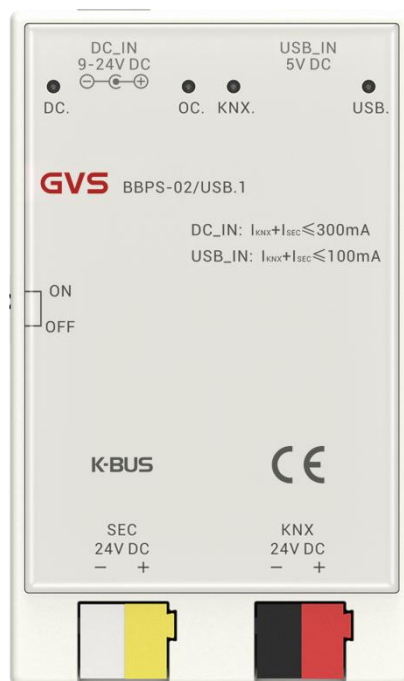

KNX/EIB Home and Building Control System

Attentions

1. Please keep devices away from strong magnetic field, high temperature, wet environment;

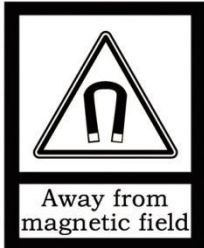

2. Do not fall the device to the ground or make them get hard impact;



3. Do not use wet cloth or volatile reagent to wipe the device;



4. Do not disassemble the devices.

Contents

Chapter 1 Summary -----	1
Chapter 2 Technical Data -----	2
Chapter 3 Dimension and Structural Diagram -----	4
3.2.Dimension Diagram -----	4
3.3.Structural Diagram -----	5
Chapter 4 Operational description of KNX USB interface -----	6
Chapter 5 Normal working test and Attention of Output -----	7

Chapter 1 Summary

KNX Commissioning is designed for an intelligent building control system, which is used for producing and monitoring KNX system voltage, and also used for facilitating communication between the PC and the KNX system.

The device supports 2 power supply: DC interface and Type-C interface. It has 2 outputs, one designated for auxiliary voltage output and the other for KNX bus power and communication.

The device can connect the USB communication interface to the computer through a standard type C USB3.0 interface extension line, and the other end of the device can be connected to the KNX bus via a bus connection terminal. If the KNX bus on the device side is long enough, it can also be directly connected to the computer without USB extension line.

The device has not an application program. Through the ETS software (version ETS5 and above) in the computer of this device, the individual address, configuration parameters, debugging and bus monitoring of the KNX device can be assigned.

KNX Commissioning supports extended frames and long telegrams with up to 55 bytes APDU length. Due to HID profile support, no specific USB driver is required. The protocol used for communication between interface and host is the flexible “cEMI” protocol.

Chapter 2 Technical Data

Power Supply	Input voltage	DC, 9~24V DC; Type-C, 5V DC
Output	KNX nominal voltage	1 line with integrated choke, 24~26V DC
	Auxiliary voltage output	1 line without integrated choke, 24~26V DC
	Nominal current	DC, ≤300mA (Only 24V DC can reach 300mA) Type-C, ≤100mA
	Sustained short-circuit current	Only Type-C, <300mA
Interface	Type-C interface, USB Standard 2.0	
Connection	KNX output	Bus connection terminal(Red/Black)
	Auxiliary voltage output	Connection terminal (Yellow/White)
	Input	DC interface(DC-005 5.5-2.1mm) Type-C interface
	PC connection	Via USB socket type A Max.cable length 3m (standardized) Only supports Type-A to Type-C data cables
Operation and display	DC power supply indicator LED	Green: power supply normal
	Type-C power supply indicator LED	Green: power supply normal

	KNX communication indicator LED Type-C short circuit indicator LED Power supply switch	Green: PC connection normal Green flashing: in PC communication Red: KNX connection normal Red flashing: in KNX communication Red off: KNX connection abnormal Red flashing: power supply abnormal, it is short circuit Red off: power supply normal ON: enable power supply OFF: disable power supply
	KNX interface version	v70 or higher
Temperature	Operation	- 5 °C ... 45 °C
	Storage	- 25 °C ... 55 °C
	Transport	- 25 °C ... 70 °C
Environment	Humidity	<93%, except dewing
Dimension	54 × 91 × 26 mm	
Weight	0.15kg	
Mounting	As required	

Chapter 3 Dimension and Structural Diagram

3.2. Dimension Diagram

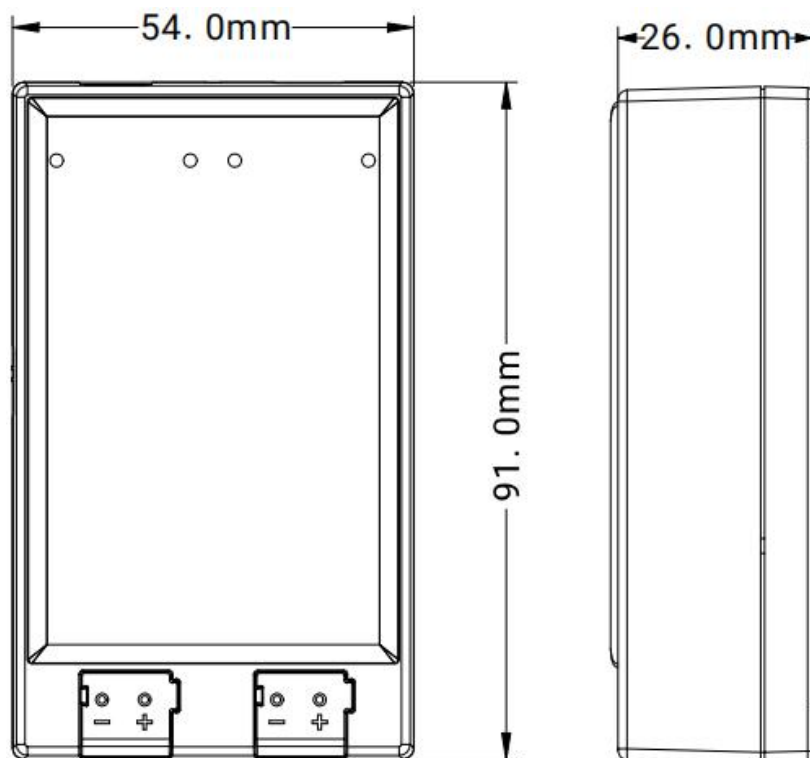

3.3. Structural Diagram

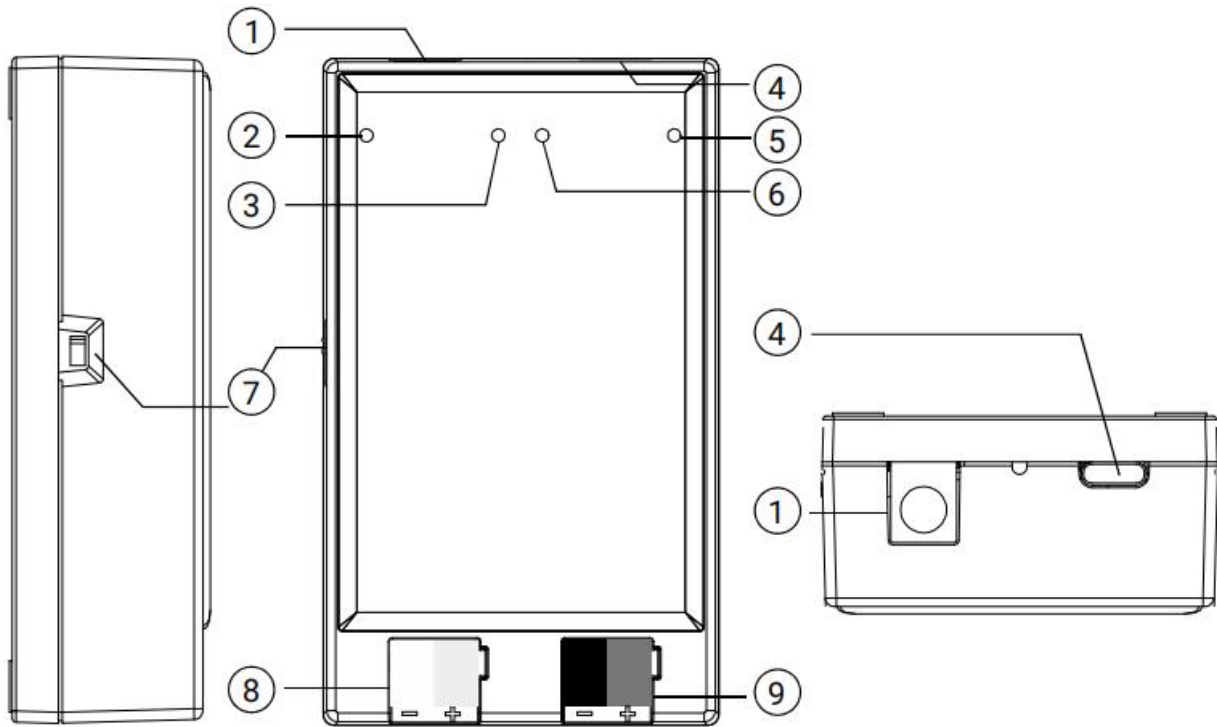

① DC power supply interface

② DC power supply indicator LED

③ Type-C short circuit indicator LED

④ Type-C power supply interface/
KNX bus connection interface

⑤ Type-C power supply indicator LED

⑥ KNX communication indicator LED

⑦ Power supply switch

⑧ Connection terminal (Auxiliary voltage output)

⑨ Bus connection terminal (KNX output)

Chapter 4 Operational description of KNX USB interface

After the USB interface and KNX bus connection of this device are normal, we will see its default configuration in the bus connection window of the ETS, as follows:

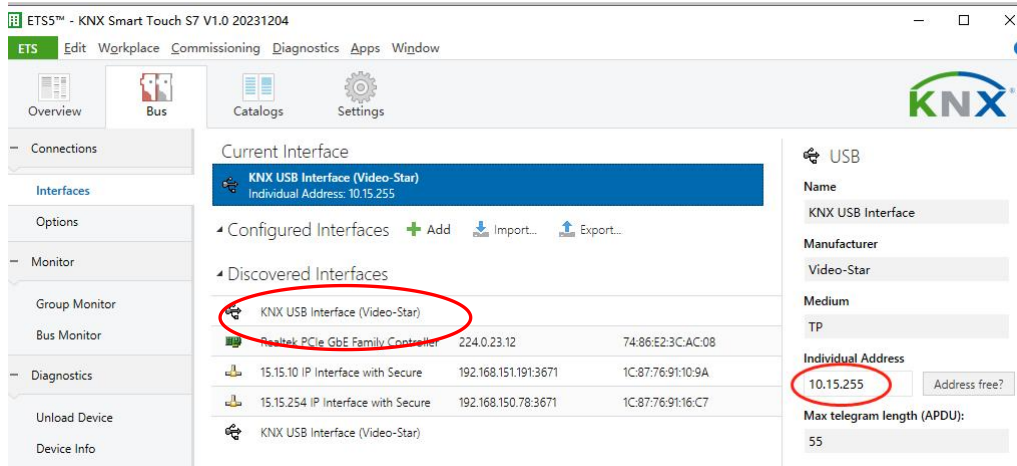

Fig.4.1 Bus connection window for ETS5--Individual address assignment (1)

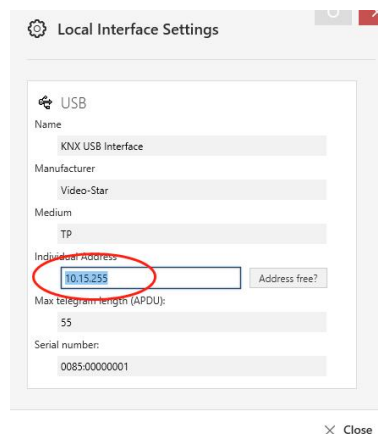
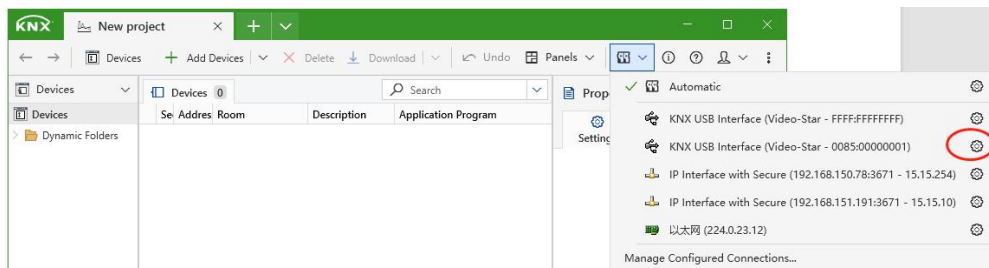

Fig.4.1 Bus connection window for ETS6--Individual address assignment (2)

In general, in the KNX topology system, it is necessary to set the correct individual address for the device according to the topology location of the device in the ETS bus connection window in Figure 4.1.

Chapter 5 Normal working test and Attention of Output

When KNX Commissioning has been correctly installed, switch on the main power supply for KNX Commissioning, and the **Power supply indicator LED** is at a green light, that is, the device function correctly.

Attention:

The **DC power supply indicator LED** and **Type-C power supply indicator LED** of KNX Commissioning can only indicate that the input is normal, if the load current is too large but not up to the over current, there is no any indication. When the DC power supply is 24V, the nominal current can be up to 300mA, you can choose the appropriate DC power supply according to the load current.